

IN INSULATION STUDS

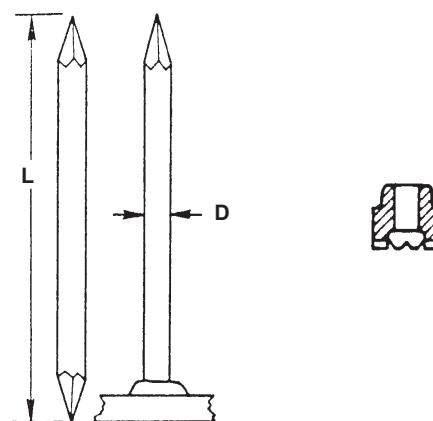
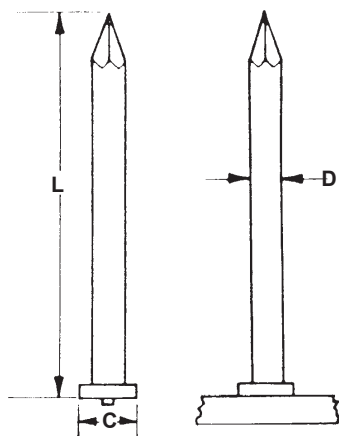

CD STYLE		
D	C	L
12 ga.	.170	as required
10 ga.	.187	as required

ARC STYLE DOUBLE POINT		
D	Min L	FERRULE
10 ga.	3/4	10GFER
3/16	3/4	31FER

COX INDUSTRIES IN STUDS are available in CD and ARC style. All orders for ARC studs include required ferrules.

MATERIAL: Low carbon steel.

ALUMINUM: Studs are available in weldable aluminum alloys.

STAINLESS STEELS: COX INDUSTRIES studs are also available in weldable stainless steel. Type 304 is the most commonly used. Other grades of stainless steel (except Type 303) available when required.